

# Sara-Lorea-Abodi-Andrea

---

## Instruction Book



**LACUNZA®**

Lacunza congratulates you on your choice.  
Certified under ISO 9001, Lacunza guarantees the quality of its appliances and undertakes to meet the needs of its customers.

Confident of the know-how afforded by more than 50 years' experience, Lacunza uses advanced technologies in the design and manufacture of its entire range of appliances. This document will help you install and use your appliance in optimum conditions for your comfort and safety.

## CONTENTS

1. PRESENTATION OF THE APPLIANCE .....	3
1.1. General characteristics .....	3
2. INSTRUCTIONS FOR THE INSTALLER.....	6
2.1. Warning to installers .....	6
2.2. Room for installation .....	6
2.2.1. Ventilation of the room .....	6
2.2.2. Location of the appliance in the room .....	7
2.3. Installation of the appliance .....	7
2.3.1. Floor .....	7
2.3.2. Safety distances .....	7
2.3.3. Checks before lighting for the first time .....	7
2.3.4. Height adjustment and levelling the appliance .....	7
2.3.5. Casing .....	7
2.3.6. Connection to the flue.....	8
2.3.7. Piping air to other rooms (Andrea / Abodi) .....	8
2.4. Chimney flue .....	9
2.4.1. Type of flue.....	9
2.4.2. Chimney crown.....	10
3. INSTRUCTIONS OF USE .....	11
3.1. Fuel .....	11
3.2. Description of the parts of the appliance .....	12
3.2.1. Operating components .....	12
3.3. Lighting .....	13
3.4. Loading fuel .....	13
3.5. Operation .....	13
3.6. Removing ash .....	14
3.7. Deflectors. Flapper valve .....	15
3.8. Electrical system.....	15
4. MAINTENANCE AND IMPORTANT ADVICE.....	16
4.1. Maintenance of the appliance.....	16
4.1.1. Firebox .....	16



4.1.2. Inside the appliance .....	16
4.1.3. Flue socket .....	16
4.1.4. Firebox glass.....	16
4.2. Maintenance of the chimney flue.....	16
4.3. Important advice.....	16
5. TROUBLESHOOTING.....	17
6. BASIC BREAKDOWNS .....	18
7. DECLARATION OF PERFORMANCE.....	20
8. CE MARK.....	24

## 1. PRESENTATION OF THE APPLIANCE

For optimum operation of the appliance, we advise you to read this manual carefully before switching on the appliance for the first time. In case of problems or concerns, we urge you to contact your dealer, who will cooperate with you.

In order to improve the product, the manufacturer reserves the right to make changes without notice by updating this document.

This appliance is designed to burn wood in absolutely safe conditions.

**WARNING:** Faulty installation may have serious consequences.

Installation and all necessary regular maintenance operations must be performed by an authorized installer in full accordance with the specifications set out in the legislation applicable in each country and this instruction book.

### 1.1. General characteristics

	Unit	Sara-Lorea	Abodi-Andrea
Nominal Heat Output (N.H.O.) to atmosphere	kW	20	19
Efficiency at N.H.O.	%	80	76
CO emission at 13% O <sub>2</sub> at N.H.O.	%	0.09	0.39
Gas mass flow at N.H.O.	g/s	15.3	19
Gas temperature downstream of flue socket at N.H.O.	°C	297	400
Optimum flue draught	Pa	12	12
Wood consumption (beech) at N.H.O.	Kg/h	5.8	6.4
Dimensions of the firebox			
Width	mm	700	700
Depth	mm	435	435
Useful height	mm	500	500
Dimensions of the logs			
Volume heated (45w/m <sup>3</sup> ) at N.H.O.	m <sup>3</sup>	422	422
Log load frequency	h	1	1
Capacity of the ashpit	L	3.2	3.2
Weight	kg	160	275
Flue socket diameter	mm	250	250
Voltage (AC)	V	230	230
Frequency	Hz	50	50

**Note:** The values indicated in the above table are based on tests performed in accordance with UNE-EN 13229, with logs with no more than 18% humidity and pressure conditions as indicated in each case.

**Warning:** this appliance is designed and prepared to work with the types of fuel, degree of humidity of the fuel, fuel loads, fuel load frequencies, flue draught and system of installation indicated in this Instruction Book. Failure to respect these conditions may lead to problems with the appliance (deterioration, shorter useful life, etc.) which are not covered by the Lacunza warranty.

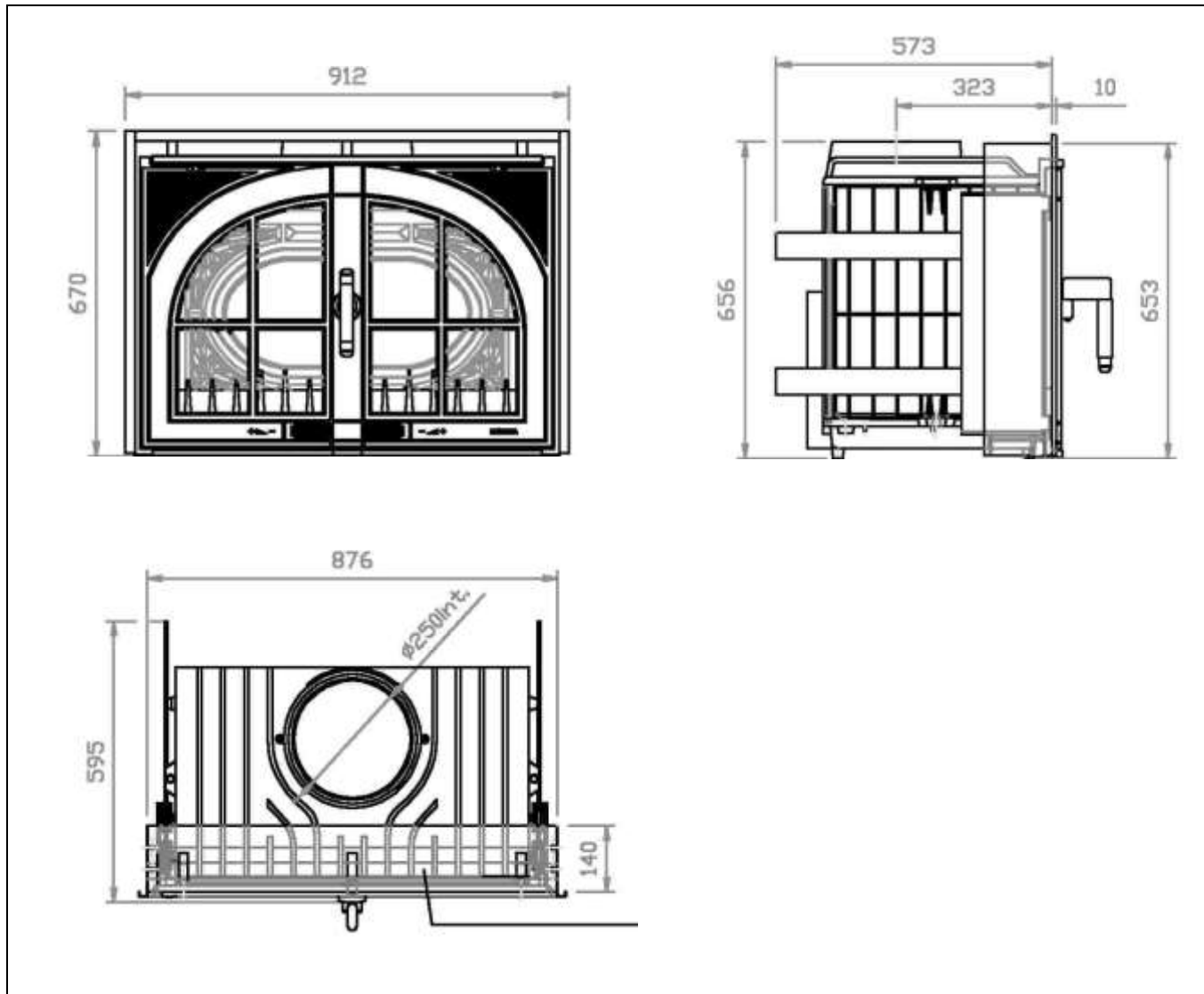

Figure No.1 - Dimensions of the Sara-Lorea appliance in mm

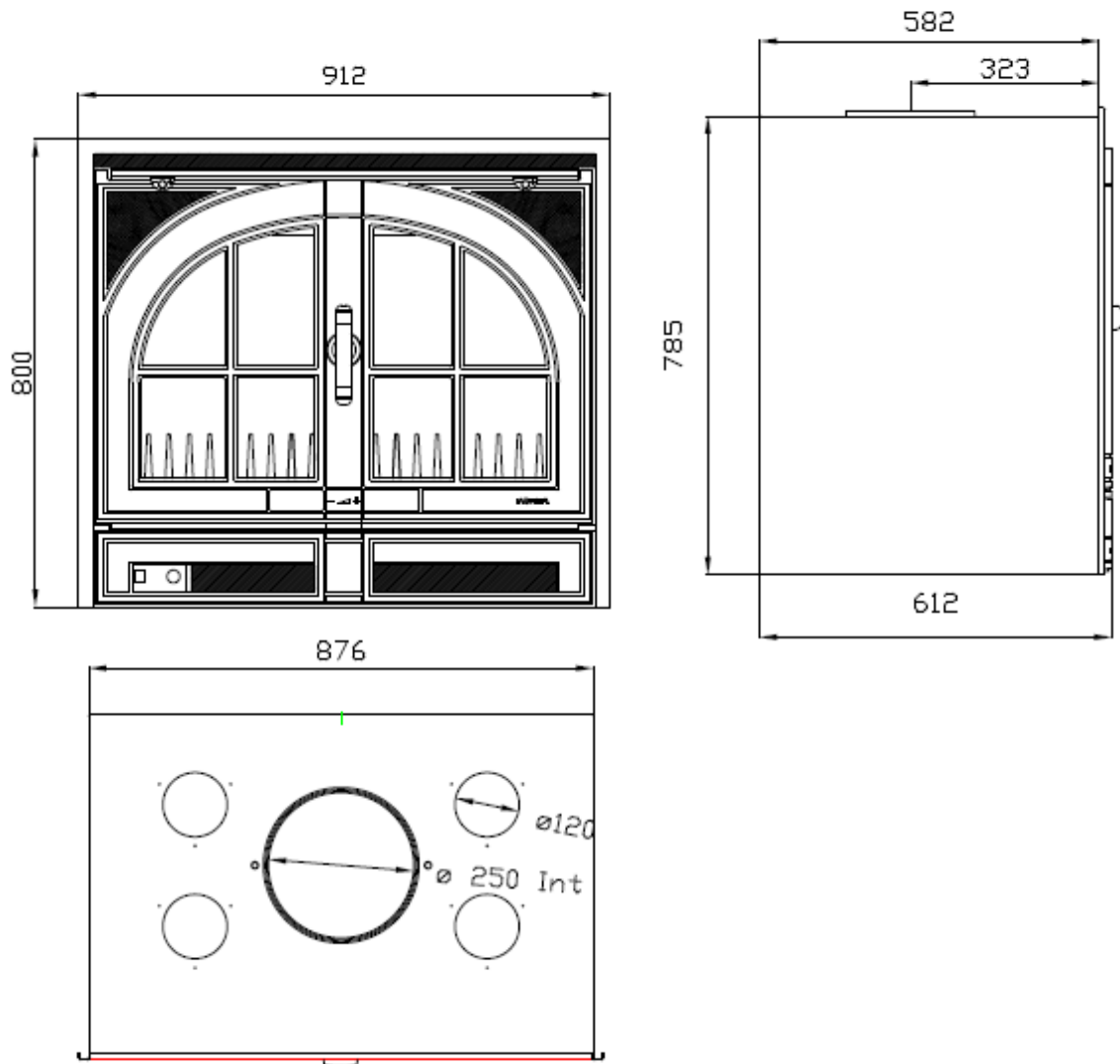

Figure No.2 - Dimensions of the Abodi-Andrea appliance in mm

## 2. INSTRUCTIONS FOR THE INSTALLER

### 2.1. Warning to installers

All local and national regulations, including all those referring to national and European standards, must be observed when installing the appliance.

Installation of the appliance must be performed by an authorised installer.

An incorrectly installed appliance may lead to serious incidents (fires, creation of harmful gases, deterioration of nearby fixtures, etc.).

Lacunza's liability is limited to the supply of the material and does not include installation of the appliance.

### 2.2. Room for installation

#### 2.2.1. Ventilation of the room

The appliance needs to consume oxygen (air) in order to work properly. Ensure a suitable air supply in the room in which the appliance is fitted. This quantity of oxygen is additional to the oxygen that we need in order to breathe (air renewal).

In order to ensure the high quality of the air you breathe and to avoid potential accidents resulting from high concentrations of the gases produced by combustion (mainly carbon dioxide and carbon monoxide), it is absolutely crucial to ensure the suitable renewal of the air in the room in which the appliance is fitted.

The room must always have at least two permanent grilles or openings to the exterior in order to renew the air (one for intake and the other for extraction).

For the installation of its appliances, Lacunza recommends an additional section for these openings. One of these two grilles must be situated high up in the room (at less than 30 cm from the ceiling)

and the other one low down (at less than 30 cm from the floor). Both grilles must open outdoors in order to renew the air in the room with fresh air.

The minimum section that each of these grilles must have depends on the nominal output of the appliance in accordance with the following table:

Output of the appliance (kW)	Minimum additional section of each of the grilles (cm <sup>2</sup> )
$P \leq 10\text{kW}$	70
$10 < P \leq 15$	90
$15 < P \leq 20$	120
$20 < P \leq 25$	150
$25 < P \leq 30$	180
$30 < P \leq 35$	210
$P > 35$	240



Figure No.3 - Guideline indications for ventilation grilles

The appliance must always be used with the door(s) closed.

In rooms equipped with Controlled Mechanical Ventilation, the system extracts and renews the ambient air; in such cases, the room is at slightly low pressure and it is necessary to install a non-closable outside-air inlet with a section of at least 90 cm<sup>2</sup>.

### 2.2.2. Location of the appliance in the room

Choose a location in the room which favours good hot-air distribution by convection and radiation.

## 2.3. Installation of the appliance

### 2.3.1. Floor

Make sure that the base can withstand the total constructed weight of the appliance and its casing.

When the floor surface (base) is combustible, fit suitable insulation.

### 2.3.2. Safety distances

Be sure to respect the appliance installation distances from **combustible materials**. Looking at the appliance head-on:

	Distance to combustible materials (mm)
From the right-hand side	150
From the left-hand side	150
From the rear	200
From the front	1000

Bear in mind that it may even be necessary to protect non-combustible material in order to prevent breakage, deformation, etc., as a result of overheating if the non-combustible material is not designed to withstand high temperatures.

### 2.3.3. Checks before lighting for the first time

- Make sure that the glass/es is/are not broken or damaged.
- Make sure that the flueway is not obstructed with packing or loose parts.
- Make sure that the airtight joints on the flue circuit are in perfect condition.

- Make sure that the doors close properly.
- Make sure that all moving parts are fitted in place.

### 2.3.4. Height adjustment and levelling the appliance

The appliance must be perfectly level, horizontally and vertically, both at the front and on the sides (use a spirit level).

### 2.3.5. Casing

Make sure that the material around the appliance is not flammable or likely to deteriorate as a result of heat (wallpaper, carpet, plastic-based casing, Silestone, etc.).

The image below gives an example of how the appliance can be encased properly:

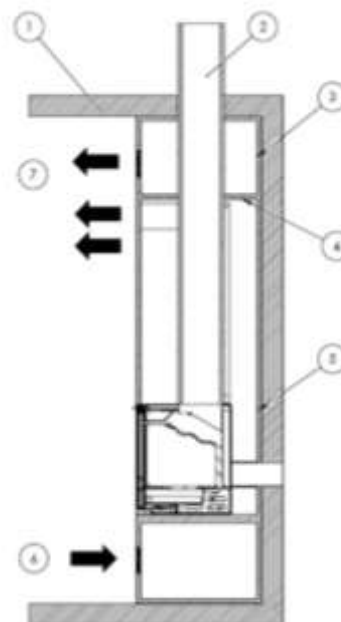

Figure No.4 - Interior diagram of the casing

**Key to casing diagram:**

- 1 Ceiling
- 2 Flue
- 3 Incombustible material (Inner hood insulation)
- 4 Insulating deflector made of incombustible material
- 5 Wall
- 6 Fresh-air inlet (1,000 cm<sup>2</sup>)
- 7 Hot-air outlet (1,000 cm<sup>2</sup>)

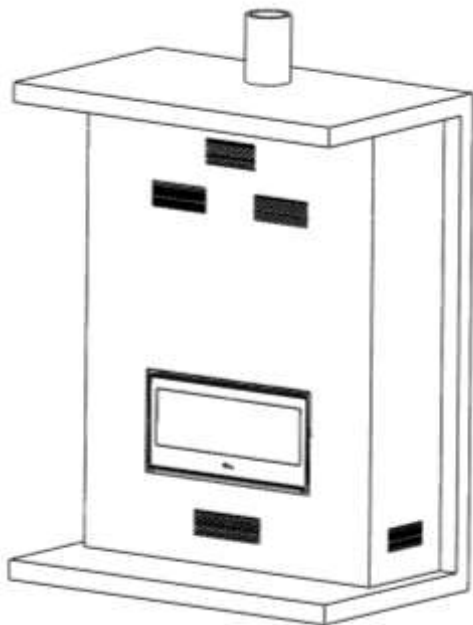

Figure No.5 - Exterior diagram of the casing

In order to enable suitable air circulation and correct operation, the casing must have a fresh-air inlet with a minimum section of 1,000cm<sup>2</sup> beneath the level of the actual appliance and a hot-air outlet measuring at least 1,000cm<sup>2</sup> above it (just before the insulating deflector inside the casing). These inlet and outlet sections must ensure air renewal in such a way as to avoid damage to parts inside the hood due to excess temperature.

A further hot-air ventilation grille is also recommended between the insulating deflector on the hood and the ceiling.

On non-central-heating appliances (without back boiler), Lacunza does not recommend enveloping the outside of appliances with insulation.

The installer must fit the necessary inspection accesses (trap doors, hatches, etc.) so that everything inside the hood that may need maintenance work or replacement can be accessed at any time, e.g. counterweight system, hydraulic components, heating circuit safety components.

### 2.3.6. Connection to the flue

The appliance must be connected to the chimney flue using special piping designed to resist the products of combustion (e.g. stainless steel, enamelled steel, etc.).

To connect the flue to the socket flange, insert the piping inside the flange and seal the joint with fire sealant or fire cement to make it completely airtight.

The installer must ensure that the pipe connected to the appliance is well secured and there is no chance of it coming free from its housing (e.g. as a result of dilatation due to temperature, etc.).

### 2.3.7. Piping air to other rooms (Andrea / Abodi)

It is possible to pipe some of the heat generated to other rooms in the house using the appliance. This does not mean that the appliance works more efficiently, but it does mean that the heat it creates is distributed better. For this purpose, in the top surface of the appliance there are 2 potential hot-air outlets with diameters of 120mm on the top shell of the appliance. Pipes can be fitted from these outlets to other rooms. If you intend to do this, bear the following points in mind.

- Do not break the scored steel circles completely. Simply bend them in order to facilitate the conduction of heat to the pipe.

- The air ducts must always be heat insulated and smooth inside (not corrugated).
- The pipes must always have an upward slant to facilitate movement by air density.
- On routes with a lot of load loss (a lot of retention), air movement can be forced along the ducts using a motor or fan, provided that it is designed to withstand such temperature conditions.

Bear in mind that air ducts mean that noise travels more easily from one room to another.

## 2.4. Chimney flue

The chimney flue must comply with present standards on the installation of chimneys.

In rooms equipped with Controlled Mechanical Ventilation, the ventilation outlet must never be connected to the flue.

The appliance must always have its own chimney flue, never sharing a chimney flue with another appliance.

### 2.4.1. Type of flue

The flue must be made of special material designed to resist the products of combustion (e.g. stainless steel, enamelled steel, etc.).

Non-central-heating appliances (without back boiler) require an insulated, double-sleeve flue only on those sections that run outdoors or through cold areas. Single piping can be used inside the building, the heat of the gases serving to heat rooms, insulating only those sections where excess temperature may cause damage.

If the chimney is constructed, then it is necessary to pipe and insulate it to ensure correct updraught.

The diameter of the pipe must be the same as the diameter of the flue socket on the appliance over its entire length in order to ensure correct operation.

The flue must prevent the entry of rainwater.

The flue must be clean and airtight over its entire length.

The flue must be at least 6m tall and the chimney cap must not hinder the free release of gases.

If the flue tends to suffer from downdraught, then it is necessary to fit an effective anti-downdraught cowl, a static cowl or a smoke extraction fan, or reshape the chimney.

Never make 90° bends, due to the great loss of draught they cause, and reduce 45° bends down to an absolute minimum. Each 45° bend is equivalent to a 0.5m reduction in flue length. Horizontal flue sections should not be installed because they cut updraught a great deal.

If the flue draws at more than 20 Pa on 12Pa appliances and more than 25Pa on 17Pa appliances, then an effective damper must be fitted on the flueway. This damper must be visible and accessible.

The chimney flue must not rest on the appliance.

Bear in mind that high temperatures may be reached in the flue, meaning that it is essential that insulation be enhanced in sections in which combustible material is present (wooden beams, furniture, etc.). It may even be necessary to protect non-combustible material in order to prevent breakage, deformation, etc., as a result of overheating if the material is not designed to withstand high temperatures.

It must be possible to clean the entire flue, no sections being left inaccessible for cleaning purposes.

### 2.4.2. Chimney crown

The upper end of the chimney must clear the roof, the roof ridge or any obstacle located on the roof by at least 1m.

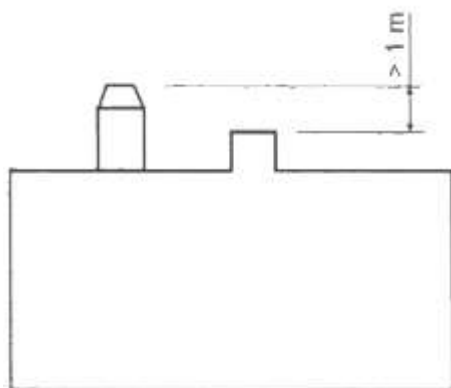
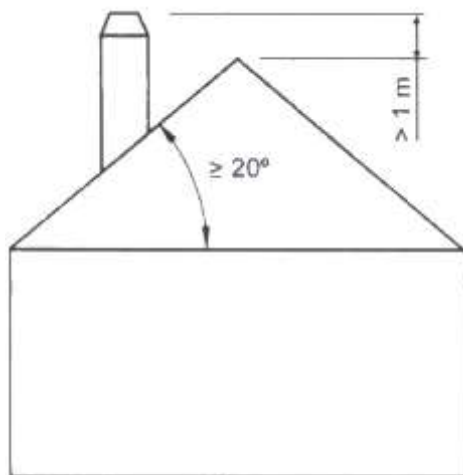
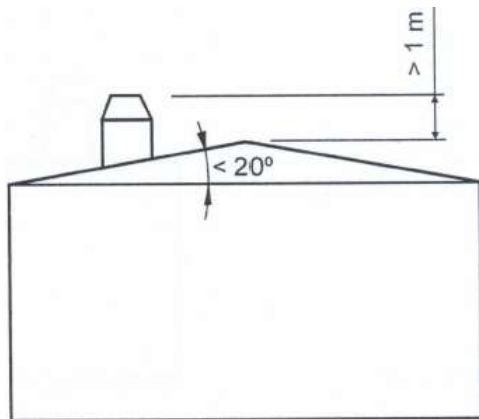

Figure No.6 - Distances between chimney crown and roof ridge

The chimney crown must clear the highest point of any neighbouring building or obstacle located within a 10m radius of the chimney outlet by more than 1m.

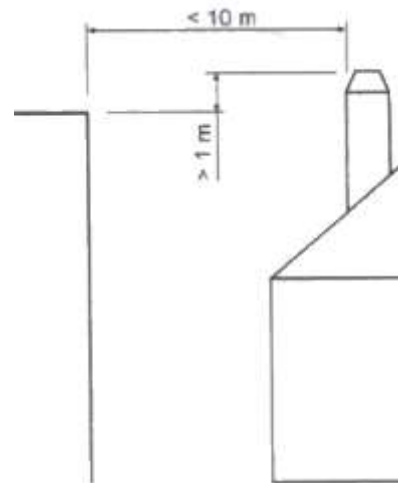

Figure No.7 - Distances between the chimney crown and objects within a 10m radius

The chimney crown must clear any neighbouring building or obstacle located within a radius of 10m to 20m from the chimney outlet.

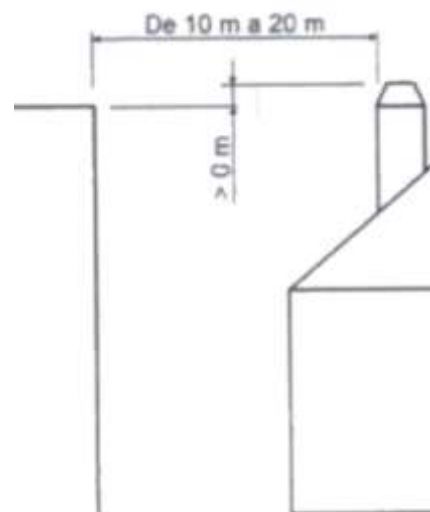

Figure No.8 - Distances between the chimney crown and objects within a radius of between 10 and 20m

### 3. INSTRUCTIONS OF USE

The manufacturer accepts no liability whatsoever for damage caused to parts as a result of the improper use of non-recommended fuels, modifications made to the appliance or how it is installed.  
**Only use original replacement parts.**

All local and national regulations, including those referring to national and European standards, must be observed when using the appliance.

Heat is diffused by radiation and convection via the front and exterior of the appliance.

#### 3.1. Fuel

This appliance must not be used as an incinerator. Do not use non-recommended fuels.

- Use dry logs (max. 16% humidity), cut at least 2 years ago, clean of resin and stored in a sheltered, ventilated place.
- Use hard woods with high calorie values and good ember production.
- Large logs should be cut to useable lengths before being stored. The logs should have a maximum diameter of 150mm.
- Finely-chopped wood produces greater heat output, but also burns more quickly.

Optimum fuels:

- Beech.

Other fuels:

- Oak, chestnut, ash, maple, birch, elm, etc.
- Pine and eucalyptus logs are low density and produce very long flames, and may cause the parts of the

appliance to wear out more quickly than normal.

- Resinous wood may mean that the appliance and the flue need to be cleaned more often.

Non-permitted fuels:

- All types of coal and liquid fuel.
- “Green wood”. Green or damp wood reduces the performance of the appliance and leads to soot and tar build-up on the inner walls of the flue, obstructing it.
- “Recovered wood”. The burning of treated woods (railway sleepers, telegraph posts, plywood, fibreboard, pallets, etc.) quickly blocks the system (soot and tar build-up), harms the environment (pollution, smells) and may lead to deformation of the firebox due to overheating.
- All materials which are not wood (plastic, spray cans, etc.).

Green and reprocessed wood may cause chimney fires.

The graph below shows how the humidity of firewood affects its heat output:

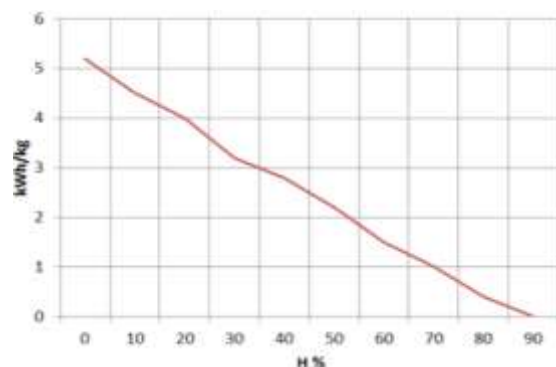

Figure No. 9 - Relationship between firewood humidity and heat output.

## 3.2. Description of the parts of the appliance

### 3.2.1. Operating components

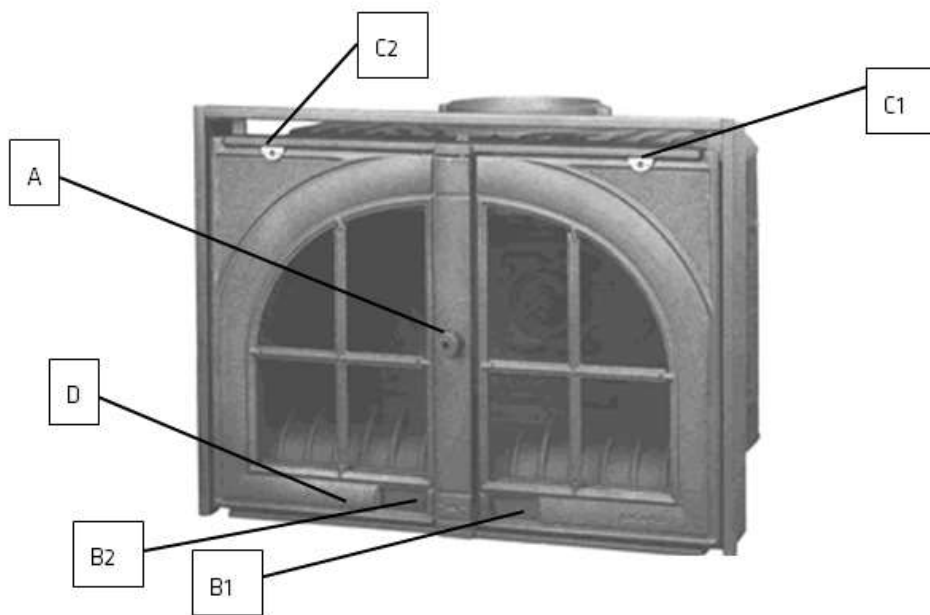

Figure No.10 - Operating components on the appliance

- A: Firebox door handle
- B: Primary air intake
  - B1 open (move right)
  - B2 open (move left)
- C: Secondary air intake
  - C1 open (move towards the + symbol)
  - C2 open (move towards the + symbol)
- D: Double-combustion air intake
  - Opening left door

### 3.3. Lighting

Use of the appliance in warm weather (warm days, early hours of the afternoon on sunny days) may lead to lighting and updraught problems.

Certain weather conditions, such as fog, ice, humidity entering the flue, etc., may hinder sufficient updraught in the flue and lead to suffocation.

Proceed as follows in order to light the appliance satisfactorily:

- Open the firebox door(s) and open all the firebox air-intake inlets to the full.
- Place paper or a firelighter and some wood chips in the firebox.
- Light the paper or firelighter.
- Leave the door slightly ajar, the width of two or three fingers, for about 15 minutes until the glass warms up.
- The first time the appliance is lit, the fire should be gentle to allow the parts of the appliance to dilate and dry.

**Important:** The first time it is lit up, the appliance may give off smoke and strange smells. This is not a cause for concern. Open an outdoor window to ventilate the room during the first few hours of operation.

If you notice water around the appliance, this is produced by the condensation of the moisture in the wood on lighting the fire. This condensation will no longer appear when the appliance has been lit three or four times and has adapted to its flue. If it does not disappear, then check the flue draught (length and diameter of the flue, flue insulation, airtightness) and the humidity of the wood used.

### 3.4. Loading fuel

In order to load firewood, open the firebox door gently (both doors at the same time), preventing the sudden entry of air to the firebox so that smoke does not enter the room that the appliance is installed in.

Perform this operation with the glove to prevent burns to the hands.

The maximum load height is 2 logs with diameters of approx. 10 cm.

The minimum interval between loads for nominal heat output is 60 minutes.

Always load with the nominal amount (see table in section 1.1).

For minimum burning (e.g. at night), use thicker logs.

When the firebox is loaded, close the door.

Be careful when placing logs in the firebox on appliances with vermiculite interiors. Vermiculite is a fragile material and may crack if knocked.

### 3.5. Operation

The appliance should be operated with the doors closed.

For safety reasons, never close all the **appliance's combustion-air** intakes.

#### Primary-air intake

By opening this inlet, air enters the firebox via the firebox grille.

#### Secondary-air intake

By opening this inlet, air enters the firebox via the top of the firebox door.

**IMPORTANT:** Keeping the secondary-air intake open helps keep the door glass cleaner for longer.

### Double-combustion air intake

By opening this inlet, air enters the combustion flame, making for more efficient and less polluting combustion because post-combustion takes place, burning the particles which were not burned in the first combustion. This increases the performance of the appliance and reduces emissions.

**IMPORTANT:** The appliance is exposed to extreme changes in temperature and may, as a result, make noises when in operation. These noises are a natural result of expansion/contraction of the parts which make up the appliance. Do not be alarmed by noises of this kind.

In order to obtain maximum output, open all the air intakes to the firebox and in order to obtain minimum output, tend towards closing them. For normal use, we recommend you close the Primary Intake and leave the Secondary and Double Combustion Intakes open.

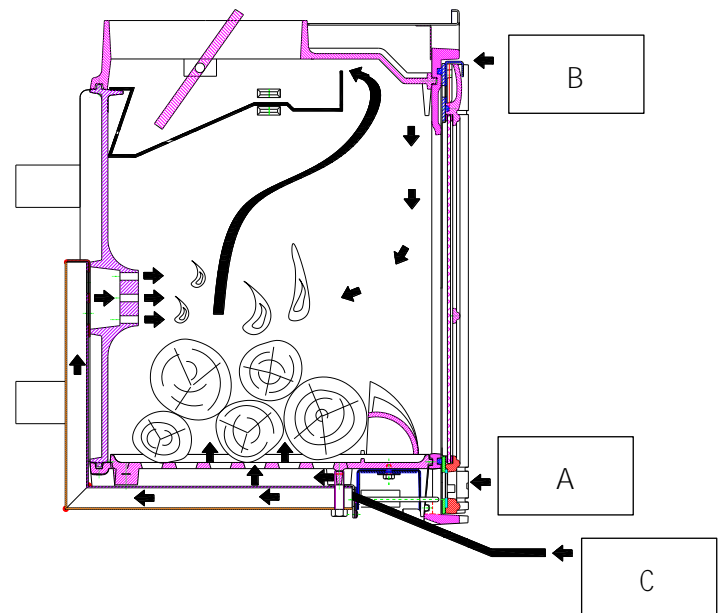

Figure No.11 - Operation

- A- Primary air
- B- Secondary air
- C- Double combustion air

### 3.6. Removing ash

Following sustained use of the appliance, it is necessary to remove the ash from the firebox. Remove the ashpit box when cold or using something to prevent yourself from getting burned (glove).

Never throw hot embers into the rubbish.

Access the ashpit by opening the door on the appliance.

### 3.7. Deflectors. Flapper valve

The appliance has an updraught-regulating flapper valve on the flue socket. This can be used to modify the section through which the gases pass and, consequently, control the updraught.

The appliance has 1 deflector.

You can see how it is fitted and regulated in the following picture.

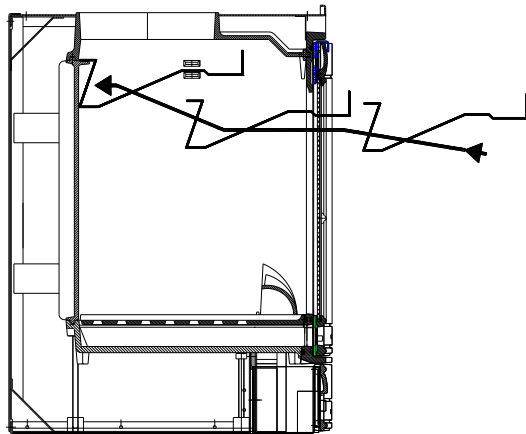

Figure No.12 - Mantling the deflector

### 3.8. Electrical system

#### Forced convection. Fans

These models have a fan for the forced convection of the hot air generated around the appliance inside the shell. This air can be piped to other rooms.

**IMPORTANT:** This appliance is not covered by our warranty unless directly connected to the mains electricity supply in accordance with the conditions described in the relevant section in 1.1.

#### Components:

M: 1 x 220V- 20W motors

T: 50°C ceramic thermostat

#### Electrical diagram:

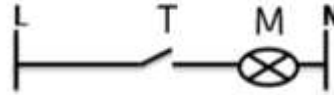

Figure No.13 - Electrical diagram for fans

#### Use:

With no fire the fans do not work.

Automatic: When the fire has been lit and the thermostat reaches 50°C, the fans start to operate automatically at medium speed. The fans stop automatically when the temperature falls beneath 50°C.

At certain moments, the fans may start up and stop several times in just a few minutes.

## 4. MAINTENANCE AND IMPORTANT ADVICE

---

### 4.1. Maintenance of the appliance

The appliance, the flue connector piping and the flue must be cleaned regularly, particularly following long periods without use.

#### 4.1.1. Firebox

Clean the firebox area of ash, etc.

#### 4.1.2. Inside the appliance

Clean the firebox area of ash. Clean the deflectors, where soot may build up.

#### 4.1.3. Flue socket

The flue socket area must be kept clean at all times for the appliance to work properly.

It must be cleaned as often as required. How often it is cleaned depends on how much the appliance is used and the type of fuel employed.

#### 4.1.4. Firebox glass

Keep the secondary-air intake open to keep the door glass cleaner for longer. However, the glass may get dirty the longer the appliance is used. Special degreasing products designed for the purpose should be used to clean it.

Clean when the glass is cold and taking care not to apply the glass cleaner directly onto the glass as it could come into contact with the door-seal cord and damage it.

Also make sure that the cleaning liquid does not enter the moving part of the intake mechanism; it may block the mechanism.

### 4.2. Maintenance of the chimney flue

**VERY IMPORTANT:** In order to avoid incidents (chimney fires, etc.), it is necessary to perform maintenance and cleaning operations on a regular basis; if the appliance is used often, then the chimney and the flue connector piping must be swept several times a year.

In the event of fire in the chimney, close the flue draught, close doors and windows, remove embers from the firebox, block the connection hole with damp cloths and call the fire brigade.

### 4.3. Important advice

Lacunza recommends that only Lacunza-authorized replacement parts be used.

Lacunza accepts no liability for any modification to the product which it has not authorized.







This appliance is a heat-producing appliance and contact may lead to burns.

This appliance may remain HOT for a period of time after it has gone out. **MAKE SURE THAT SMALL CHILDREN DO NOT GO NEAR IT.**

## 5. TROUBLESHOOTING



This symbol means that a qualified professional should be called to perform the operation.

Problem	Probable causes		Solution
The fire does not light properly The fire does not stay alight	Green or damp wood		Use hard woods, cut at least 2 years ago and stored in a sheltered, ventilated place
	The logs are too large		Use crumpled paper or firelighters and dry wood chips to light the fire. Use split logs to keep the fire going
	Poor-quality wood		Use hard woods which produce heat and embers (chestnut, ash, maple, birch, elm, beech, etc.)
	Insufficient primary air		Open the primary- and secondary-air intakes completely, or even open the door slightly. Open the outdoor-air inlet grille
	Insufficient updraught		Check that the draught is not blocked. De-soot if necessary. Check that the flue is in perfect condition (airtight, insulated, dry, etc.)
The fire flames up too much	Excessive primary air		Close the primary- and secondary-air intakes partially or totally
	Excessive updraught		Install a draught damper
Smoke given off on lighting	Poor-quality wood		Do not continually burn chips, carpentry scraps (plywood, pallets, etc.)
	Cold flue		Heat up the flue by burning a piece of paper in the firebox.
Smoke during burning	The room is at low pressure		In rooms with Controlled Mechanical Ventilation, leave an outdoor window ajar until the fire is fully alight.
	Too little wood loaded		Load as recommended. Loads notably smaller than those recommended lead to low smoke temperature and downdraught.
	Insufficient updraught		Check the condition of the flue and insulation. Check that the piping is not blocked. Clean mechanically if necessary
	Wind enters the flue		Install an anti-downdraught system (Cowl) at the top of the chimney
Does not warm up enough	The room is at low pressure		In rooms with Controlled Mechanical Ventilation, there must be an outdoor-air inlet
	Poor-quality wood		Only use the recommended fuel
The fans do not work	Electrical fault		
Water condenses (after the appliance has been lit more than 3 or 4 times)	Too little wood loaded		Load as recommended. Loads notably smaller than those recommended lead to low smoke temperature and condensation.
	Green or damp wood		Use hard woods, cut at least 2 years ago and stored in a sheltered, ventilated place.
	Condition of the flue		Lengthen the flue (5-6 metres minimum). Insulate the flue properly. Check the airtightness of the flue/appliance.

## 6. BASIC BREAKDOWNS

(NO TRADUCIR EL TEXTO DE ESTA IMAGEN)

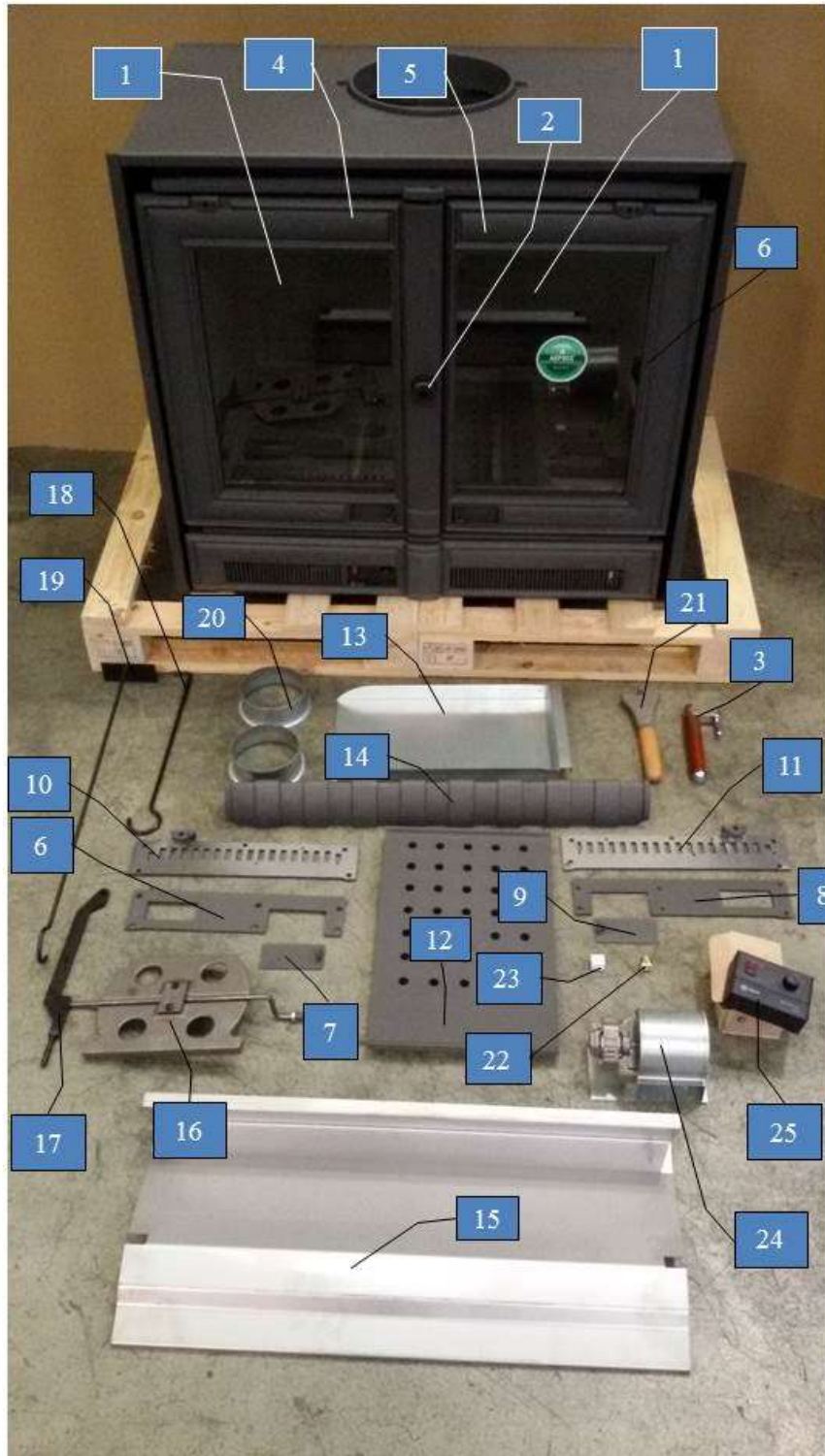

		ABODI	ANDREA	SARA	LOREA
Numero	Denominación	Ref. Pieza	Ref. Pieza	Ref. Pieza	Ref. Pieza
1	Cristal puerta hogar (izda, dcha)	504030000002	504030000002	504030000002	504030000002
2	Conjunto pestillo cierre	500000000066	500000000066	500000000066	500000000066
3	Mano fría (Manilla)	500000000075	500000000075	500000000075	500000000075
4	Cordón frente hogar Ø8mm	500900000010	500900000010	500900000010	500900000010
5	Cordón plano entre cristal y puerta 8x2mm	500000000510	500000000510	500000000510	500000000510
6	Tapa entrada aire primario izquierdo	500000000125	500000000125	500000000125	500000000125
7	Pieza movil registro entrada aire primario izdo	500000000127	500000000127	500000000127	500000000127
8	Tapa entrada aire primario derecho	500000000124	500000000124	500000000124	500000000124
9	Pieza movil registro entrada aire primario dcho	500000000850	500000000850	500000000850	500000000850
10	Registro entrada aire secundario izquierdo	500000000123	500000000123	500000000123	500000000123
11	Registro entrada aire secundario derecho	500000000122	500000000122	500000000122	500000000122
12	Parrilla hogar	500000000034	500000000034	500000000034	500000000034
13	Cajetín ceniza	504000000029	504000000029	504000000029	504000000029
14	Separador	500000000078	504060000003	500000000078	504060000003
15	Deflector	504030000004	504030000004	504030000004	504030000004
16	Cortatiros completo	504000000870	504000000870	504000000870	504000000870
17	Pieza tirador clapeta cortatiros	500000000214	500000000214	500000000214	500000000214
18	Gancho	501000000017	501000000017	501000000017	501000000017
19	Rasqueta	501000000020	501000000020	501000000020	501000000020
20	Salida aire caliente	504010000020	504010000020		
21	Agitador	500000000135	500000000135	500000000135	500000000135
22	Termostato	500900000017	500900000017		
23	Regleta cerámica	504010000011	504010000011		
24	Turbina aire	504080000007	504080000007		
25	Potenciómetro	503000000002	503000000002		

## 7. DECLARATION OF PERFORMANCE



CH-S-004

**DECLARACIÓN DE PRESTACIONES** Conforme al R. E. Productos Construcción (UE) N° 305/2011**DÉCLARATION DE PERFORMANCE** Selon le Règlement (UE) N° 305/2011**DICHIARAZIONE DI PRESTAZIONE** In base al Regolamento (UE) N° 305/2011**DECLARATION OF PERFORMANCE** According to Regulation (UE) N° 305/2011**DECLARAÇÃO DE PRESTAÇÕES** Em base com o Regulamento (UE) N° 305/2011

- Nombre y/o código de identificación única del producto:  
Nom-code d'identification unique du produit  
Nome-codice identificativo unico del prodotto  
Unique identifier name-code for product  
Nome-código de identificação único do produto
  - Marca, marque, marca, mark, marca: **Lacunza**
  - Tipo, type, tipo, type: Insertable, Appareil insérable, Apparecchio a incasso, Insertable appliance, Aparelho encastrável
  - Modelo, modèle, modello, model, modelo: **ABODI, ANDREA**
- Uso o usos previstos del producto: Aparato insertable de carga manual, para quemar combustibles sólidos (Indicado en instrucciones), cuya función es calentar el espacio en el que está instalado.  
Utilisation prévue du produit: Appareil insérable qui se charge manuellement, conçu pour brûler des combustibles solides (Indiqués dans le Manuel d'Instructions), dont la fonction est de chauffer l'espace où il est installé.  
Usi previsti del prodotto: Apparecchio a incasso a carico manuale, per bruciare combustibili solidi (indicati nelle istruzioni), la cui funzione è riscaldare lo spazio in cui è installato.  
Entended uses of the product: Insertable appliance to be loaded by hand and designed to burn solid fuels (Indicated in instructions), whose function is to heat the space in which it is installed.  
Utilização prevista do produto: Aparelho encastrável de carga manual, para queimar combustíveis sólidos (indicado nas instruções), cuja função é aquecer o espaço no qual está instalado.
- Nombre y dirección del fabricante: **LACUNZA KALOR GROUP S.A.L.**  
Nom et adresse du fabricant: **Pol. Ind. Ibarrea s/n 31800 Alsasua (Navarra) (España)**  
Nome e indirizzo del fabbricante: **Téléfono: (0034) 948563511**  
Name and adress of the manufacturer: **Fax: (0034) 948563505**  
Nome e endereço do fabricante: **Email: comercial@lacunza.net**
- Sistema de evaluación y verificación de la constancia de las prestaciones: 3  
Système d'évaluation et contrôle de la constante de performance: 3  
Sistema di valutazione e verifica della costanza della prestazione: 3  
Assessment and verification system for constancy of performance: 3  
Sistema de avaliação e verificação da regularidade do desempenho: 3
- Organismo Notificado, Laboratoire notifié, Laboratorio notificato, Laboratory notified, Laboratório notificado: **CEIS N° NB1722 Centro de ensayos, innovación y servicios**  
**Cr. Villaviciosa de Odón a Mostoles (M-856)**  
**Km 1.5 Mostoles 28935**  
Por el sistema, Selon le system, In base al system, Based on system, Em base ao system : 3.  
Documento emitido (fecha), Numéro du rapport d'essai (date), Numero rapporto di prova (data), Test report number (date), Número relação de prova (data): **LEE/032/09 (25-05-2009)**

## 6. Prestaciones declaradas, Performance déclarée, Prestazioni dichiarate, Services declare, Desempenhos declarados:

Especificaciones técnicas armonizadas, Spécifications techniques harmonisées, Specifica tecnica armonizzata, Harmonised technical specifications, Especifica técnica harmonizada EN13229:2001/A1:2002/A2:2004/AC:2006/AC:2007											
Características esenciales, Caractéristiques essentielles, Caratteristiche essenziali, Características essencials	Prestaciones, Performance, Prestazione, Services, Desempenho										
Reacción al fuego, Résistance au feu, Resistenza al fuoco, Resistance to fire, Resistência ao fogo	Cumple, Conforms, Conforme, Compliant, Em Conformidade										
Distancia mínima de seguridad a materiales combustibles, Distance minimum aux matériaux combustibles, Distanza minima da material combustibili, Minimum distance from combustible material, Distância mínima de materiais combustíveis	<table border="0"> <tr> <td>Izquierda, gauche, sinistra, left, esquerda:</td> <td>700mm</td> </tr> <tr> <td>Derecha, droite, dritto, right, direita:</td> <td>700mm</td> </tr> <tr> <td>Trasera, arrière, retro, back, traseira:</td> <td>700mm</td> </tr> <tr> <td>Delantera, avant, fronte, front, frente:</td> <td>1000mm</td> </tr> <tr> <td>Encimera, dessus, sopra, above, acima:</td> <td>750mm</td> </tr> </table>	Izquierda, gauche, sinistra, left, esquerda:	700mm	Derecha, droite, dritto, right, direita:	700mm	Trasera, arrière, retro, back, traseira:	700mm	Delantera, avant, fronte, front, frente:	1000mm	Encimera, dessus, sopra, above, acima:	750mm
Izquierda, gauche, sinistra, left, esquerda:	700mm										
Derecha, droite, dritto, right, direita:	700mm										
Trasera, arrière, retro, back, traseira:	700mm										
Delantera, avant, fronte, front, frente:	1000mm										
Encimera, dessus, sopra, above, acima:	750mm										
Temperatura humos a potencia térmica nominal, Température des fumées, Temperatura fumi, Fume temperatura, Temperatura dos gases de combustão	400 °C										
Emisión de productos de combustión, Emission des produits de combustion, Emission prodotti combustione, Combustion products emissions, Emissões de produtos de combustão	Cumple, Conforme, Conforme, Compliant, Em Conformidade										
Concentración media CO al 13% O2	0.39 %										
Desprendimiento de sustancias peligrosas	Cumple, Conforme, Conforme, Compliant, Em Conformidade										
Temperatura superficial, Température de surface, Temperatura superficiale, Surface temperatura, Temperatura superficial	Cumple, Conforme, Conforme, Compliant, Em Conformidade										
Seguridad eléctrica, Sécurité électrique, Sicurezza elettrica, Electrical safety, Segurança elétrica	Cumple, Conforme, Conforme, Compliant, Em Conformidade										
Presión máxima de servicio (palla), Pression maximale de service, Máxima pressione di esercizio, Maximum operating pressure, Máxima pressão de exercício	-										
Resistencia mecánica (para soportar una chimenea/un conducto de humos), Résistance mécanique (pour soutenir la cheminée), Resistenza mecánica (per supportare il camino), Mechanical strength (to support the fireplace), Resistência mecânica (para suportar a chaminé)	Cumple, Conforme, Conforme, Compliant, Em Conformidade										
Potencia térmica ambiente, Puissance rendue au milieu, Potenza resa all'ambiente, Power output to the environment, Potência libertada no ambiente	19.9 kW										
Potencia térmica agua, Puissance rendue à l'eau, Potenza ceduta all'acqua, Power transferred to water, Potência cedida à água	-										
Rendimiento energético, Rendement, Rendimento, Efficiency, Atuação	75.8 %										

Las prestaciones del producto identificado en el punto 1 son conformes con las prestaciones declaradas en el punto 6.  
 La performance du produit cité au point 1 est conforme à la performance declare au point 6.  
 La prestazione del prodotto di cui al punto 1 è conforme alla prestazione dichiarata di cui al punto 6.  
 The performance of the product referred to in point 1 is consistent with the declared performance in point 6.  
 As declarações do produto identificado no ponto 1, estão conformes com as prestações declaradas no ponto 6.

La presente declaración de prestaciones se emite bajo la única responsabilidad del fabricante, indicado en el punto 3.  
 Cette déclaration de performance est délivrée sous la responsabilité exclusive du fabricant cité au point 3.  
 Si rilascia la presente dichiarazione di prestazione sotto la responsabilità esclusiva del fabricante di cui al punto 3.  
 This declaration of performance is issued under the manufacturer's sole responsibility referred to in point 3.  
 É emitida a presente declaração de desempenho sob a responsabilidade exclusiva do fabricante referido no ponto 3.



Lacunza K&F Group S.A.  
 NIF A-1076000  
 Polígono Industrial "Paseo del  
 38000 Alacua (Navarra) Spain

José Julián Garciandía Pellejero  
 Director Gerente

Alsasua 01-07-2013



CH-S-005

**DECLARACIÓN DE PRESTACIONES** Conforme al R.E. Productos Construcción (UE) N° 305/2011**DÉCLARATION DE PERFORMANCE** Selon le Règlement (UE) N° 305/2011**DICHIARAZIONE DI PRESTAZIONE** In base al Regolamento (UE) N° 305/2011**DECLARATION OF PERFORMANCE** According to Regulation (UE) N° 305/2011**DECLARAÇÃO DE PRESTAÇÕES** Em base com o Regulamento (UE) N° 305/2011

- Nombre y/o código de identificación única del producto:  
Nom-code d'identification unique du produit  
Nome-codice identificativo unico del prodotto  
Unique Identifier name-code for product  
Nome-código de identificação único do produto
  - Marca, marque, marca, mark, marca: LACUNZA
  - Tipo, type, tipo, type, tipo: Chimenea, Appareil insérable, Apparecchio a incasso, Insertable appliance, Aparelho encastrável
  - Modelo, modèle, modello, model, modelo: **SARA, LOREA**
- Uso o usos previstos del producto: Chimenea de carga manual, para quemar combustibles sólidos (indicado en instrucciones), cuya función es calentar el espacio en el que está instalado.  
Utilisation prévue du produit: Appareil insérable qui se charge manuellement, conçu pour brûler des combustibles solides (indiqués dans le Manuel d'Instructions), dont la fonction est de chauffer l'espace où il est installé.  
Usi previsti del prodotto: Apparecchio a incasso a carico manuale, per bruciare combustibili solidi (indicati nelle istruzioni), la cui funzione è riscaldare lo spazio in cui è installato.  
Entended uses of the product: Insertable appliance to be loaded by hand and designed to burn solid fuels (indicated in instructions), whose function is to heat the space in which it is installed.  
Utilização prevista do produto: Aparelho encastrável de carga manual, para queimar combustíveis sólidos (indicado nas instruções), cuja função é aquecer o espaço no qual está instalado.
- Nombre y dirección del fabricante: **LACUNZA KALOR GROUP S.A.L.**  
Nom et adresse du fabricant: Pol. Ind. Ibarrea s/n 31800 Alsasua (Navarra) (España)  
Nome e indirizzo del fabbricante: Teléfono: (0034) 948563511  
Name and adress of the manufacturer: Fax: (0034) 948563505  
Nome e endereço do fabricante: Email: comercial@lacunza.net
- Sistema de evaluación y verificación de la constancia de las prestaciones: 3  
Système d'évaluation et contrôle de la constante de performance: 3  
Sistema di valutazione e verifica della costanza della prestazione: 3  
Assessment and verification system for constancy of performance: 3  
Sistema de avaliação e verificação da regularidade do desempenho: 3
- Organismo Notificado, Laboratoire notifié, Laboratorio notificato, Laboratory notified, Laboratório notificado:  
CEIS N° NB1722 Centro de ensayos, innovación y servicios  
Cr. Villaviciosa de Odón a Mostoles (M-856)  
Km 1.5 Mostoles 28935  
Por el sistema, Selon le system, In base al system, Based on system, Em base ao system : 3.  
Documento emitido (fecha), Numéro du rapport d'essai (date), Numero rapporto di prova (data), Test report number (date), Número relação de prova (data): LEE/032/09 (25-05-2009)

## 6. Prestaciones declaradas, Performance déclarée, Prestazioni dichiarate, Services declare, Desempenhos declarados:

Especificaciones técnicas armonizadas, Spécifications techniques harmonisées, Specifica tecnica armonizzata, Harmonised technical specifications, Especifica técnica harmonizada EN13229:2001/A1:2002/A2:2004/AC:2006/AC:2007											
Características esenciales, Caractéristiques essentielles, Caratteristiche essenziali, Essential features, Características essenciais	Prestaciones, Performance, Prestazione, Services, Desempenho										
Reacción al fuego, Resistance au feu, Resistenza al fuoco, Resistance to fire, Resistência ao fogo	Cumple, Conforme, Conforme, Compliant, Em Conformidade										
Distancia mínima de seguridad a materiales combustibles, Distance minimum aux matériaux combustibles, Distanza minima da materiali combustibili, Minimum distance from combustible material, Distância mínimo de materiais combustíveis	<table border="1"> <tr> <td>Izquierda, gauche, sinistra, left, esquerda:</td> <td>700mm</td> </tr> <tr> <td>Derecha, droite, diritto, right, direito:</td> <td>700mm</td> </tr> <tr> <td>Trasera, arrière, retro, back, traseira:</td> <td>700mm</td> </tr> <tr> <td>Delantero, avant, fronte, front, frente:</td> <td>1000mm</td> </tr> <tr> <td>Encimera, dessus, sopra, above, acima:</td> <td>750mm</td> </tr> </table>	Izquierda, gauche, sinistra, left, esquerda:	700mm	Derecha, droite, diritto, right, direito:	700mm	Trasera, arrière, retro, back, traseira:	700mm	Delantero, avant, fronte, front, frente:	1000mm	Encimera, dessus, sopra, above, acima:	750mm
Izquierda, gauche, sinistra, left, esquerda:	700mm										
Derecha, droite, diritto, right, direito:	700mm										
Trasera, arrière, retro, back, traseira:	700mm										
Delantero, avant, fronte, front, frente:	1000mm										
Encimera, dessus, sopra, above, acima:	750mm										
Temperatura humos a potencia térmica nominal, Température des fumées, Temperatura fumi, Fume temperatura, Temperatura dos gases de combustão	400 °C										
Emisión de productos de combustión, Emission des produits de combustion, Emission prodotti combustione, Combustión productos emisiones, Emissões de produtos de combustão	Cumple, Conforme, Conforme, Compliant, Em Conformidade										
Concentración media CO al 13% O2	0.39 %										
Desprendimiento de sustancias peligrosas	Cumple, Conforme, Conforme, Compliant, Em Conformidade										
Temperatura superficial, Température de surface, Temperatura superficiale, Surface temperatura, Temperatura superficial	Cumple, Conforme, Conforme, Compliant, Em Conformidade										
Seguridad eléctrica, Sécurité électrique, Sicurezza elettrica, Electrical safety, Segurança elétrica	-										
Presión máxima de servicio (paño), Pression maximale de service, Máxima pressione di esercizio, Maximum operating pressure, Máxima pressão de exercício	-										
Resistencia mecánica (para soportar una chimenea/un conducto de humos), Résistance mécanique (pour soutenir la cheminée), Resistenza mecánica (per supportare il camino), Mechanical strength (to support the fireplace), Resistência mecânica (para suportar a chaminé)	Cumple, Conforme, Conforme, Compliant, Em Conformidade										
Potencia térmica ambiente, Puissance rendue au milieu, Potenza resa all'ambiente, Power output to the environment, Potência libertada no ambiente	19.9 kW										
Potencia térmica agua, Puissance rendue à l'eau, Potenza ceduta all'acqua, Power transferred to water, Potência cedida à água	-										
Rendimiento energético, Rendement, Rendimento, Efficiency, Atuação	75.8 %										

Las prestaciones del producto identificado en el punto 1 son conformes con las prestaciones declaradas en el punto 6.  
 La performance du produit cité au point 1 est conforme à la performance déclarée au point 6.  
 La prestazione del prodotto di cui al punto 1 è conforme alla prestazione dichiarata di cui al punto 6.  
 The performance of the product referred to in point 1 is consistent with the declared performance in point 6.  
 As declarações do produto identificado no ponto 1, estão conformes com as prestações declaradas no ponto 6.

La presente declaración de prestaciones se emite bajo la única responsabilidad del fabricante, indicado en el punto 3.  
 Cette déclaration de performance est délivrée sous la responsabilité exclusive du fabricant cité au point 3.  
 Si rilascia la presente dichiarazione di prestazione sotto la responsabilità esclusiva del fabbricante di cui al punto 3.  
 This declaration of performance is issued under the manufacturer's sole responsibility referred to in point 3.  
 É emitida a presente declaração de desempenho sob a responsabilidade exclusiva do fabricante referido no ponto 3.



Lacunza Bazar  
 S.L. A. 1997/03  
 Polígono Industrial Suroeste  
 48100 Albasua (Bizkaia) Spain

José Julián Garcíaandía Pellejero  
 Director Gerente

Alsasua 01-07-2013



## 8. CE MARK

---



LACUNZA KALOR GROUP S.A.L

Pol. Ind. Ibarrea s/n

31800 Alsasua (Navarra) Spain

Tel.: (00 34) 948 56 35 11

Fax.: (00 34) 948 56 35 05

e-mail: [comercial@lacunza.net](mailto:comercial@lacunza.net)

Website: [www.lacunza.net](http://www.lacunza.net)

EDITION: 0

